

FORMA DA CISTERNA - FUNDO  
ESC. 1:50

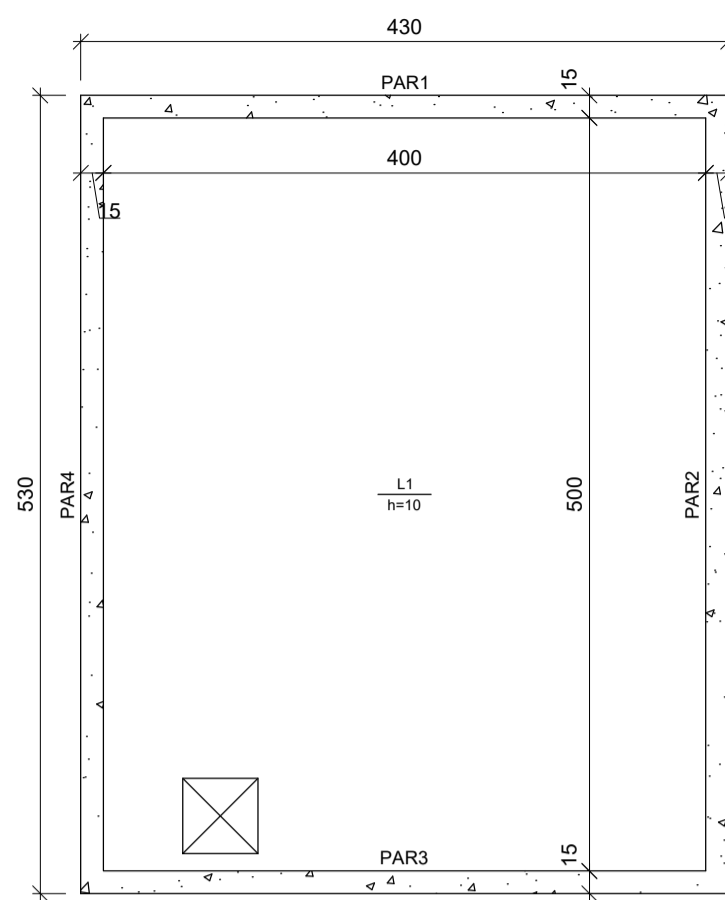

FORMA DA CISTERNA - TAMPA  
ESC. 1:50

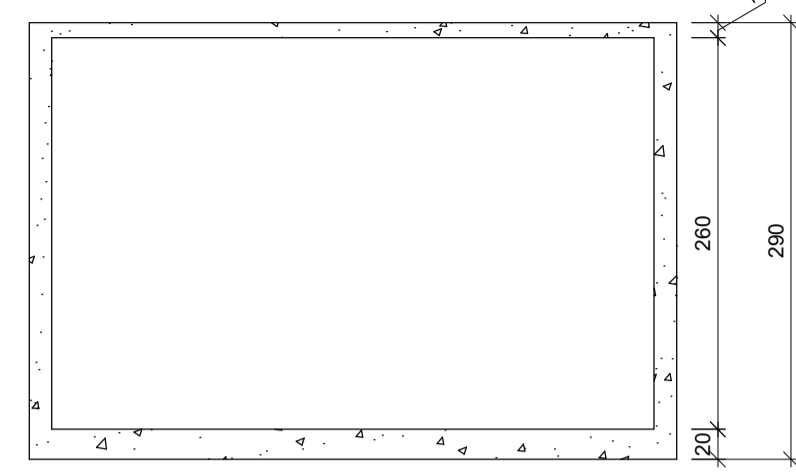

CORTE A-A  
ESC. 1:50

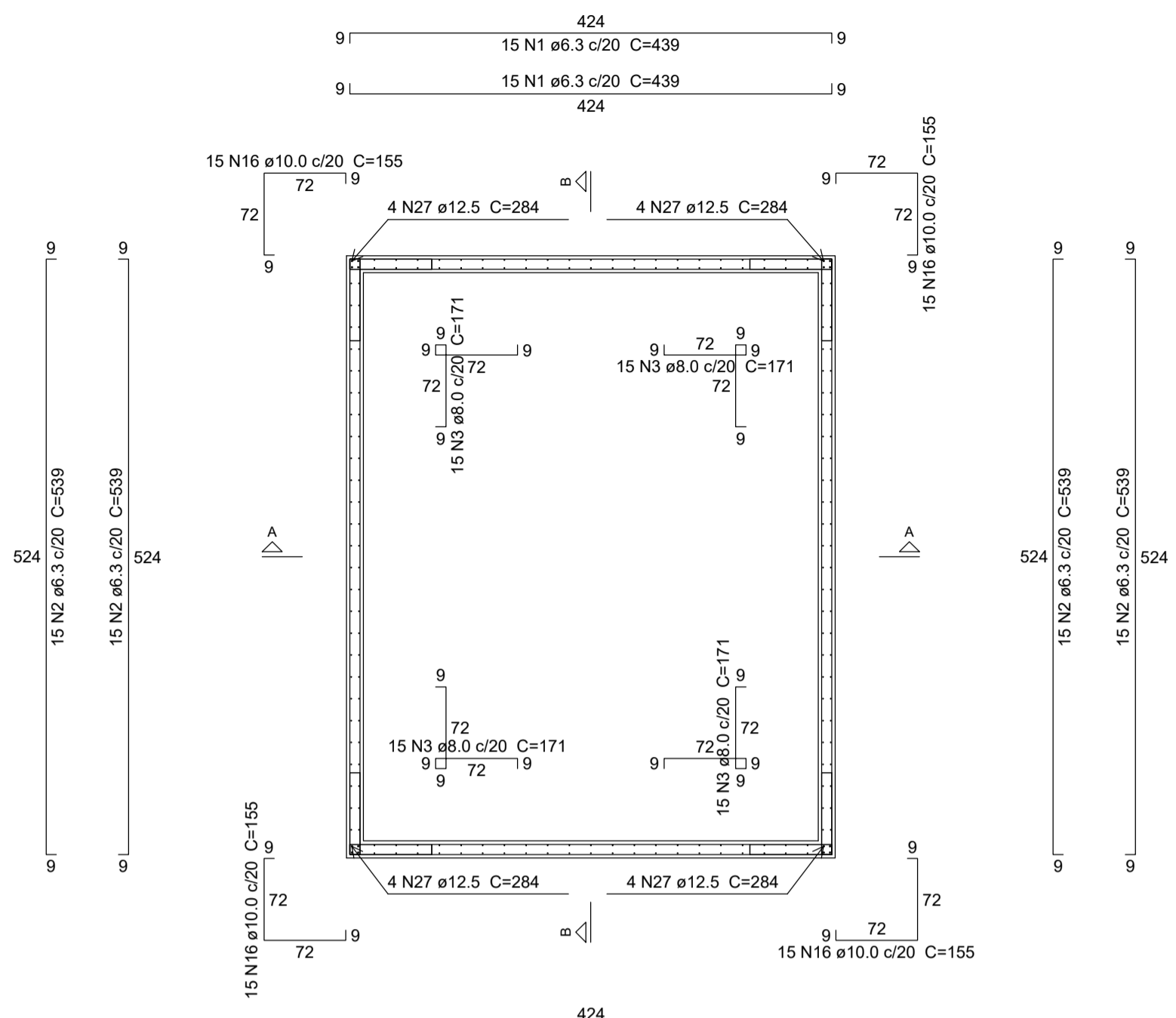

ARMAÇÃO EM PLANTA  
ESC. 1:50

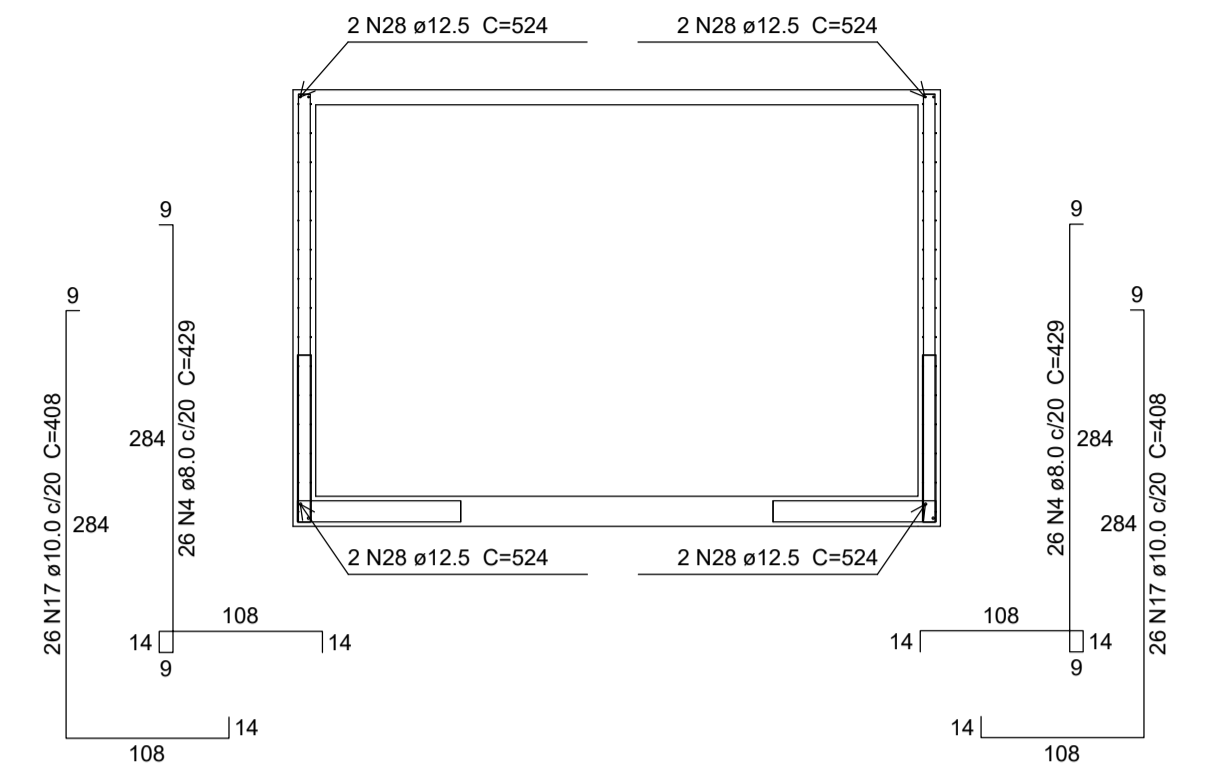

CORTE A-A  
ESC. 1:50

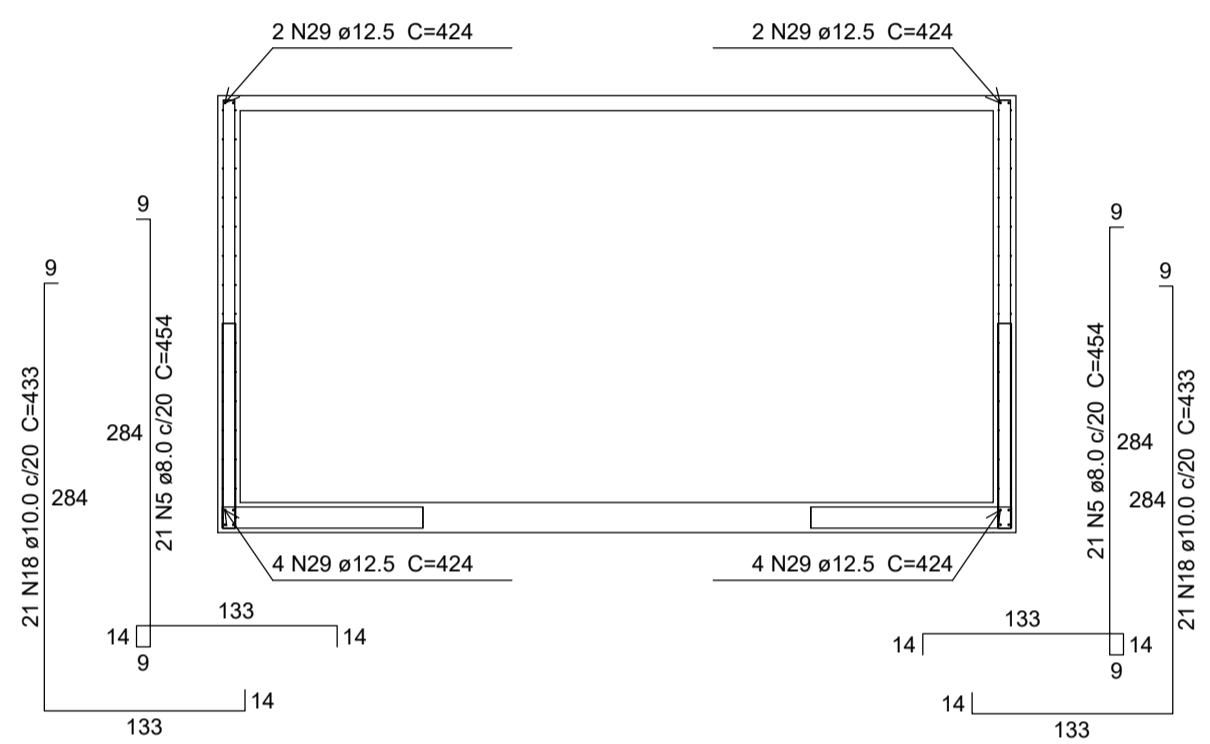

CORTE B-B  
ESC. 1:50

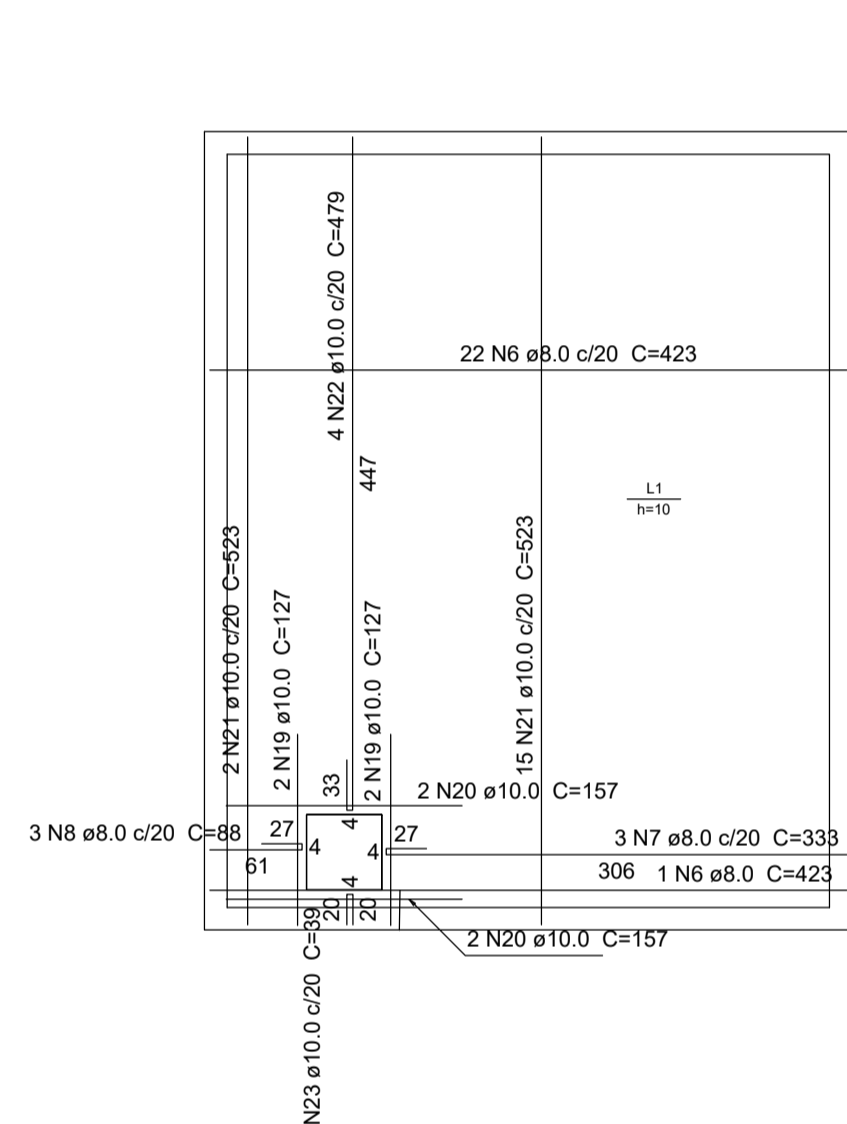

ARMAÇÃO POSITIVA DAS LAJES DE TAMPA  
ESC. 1:50

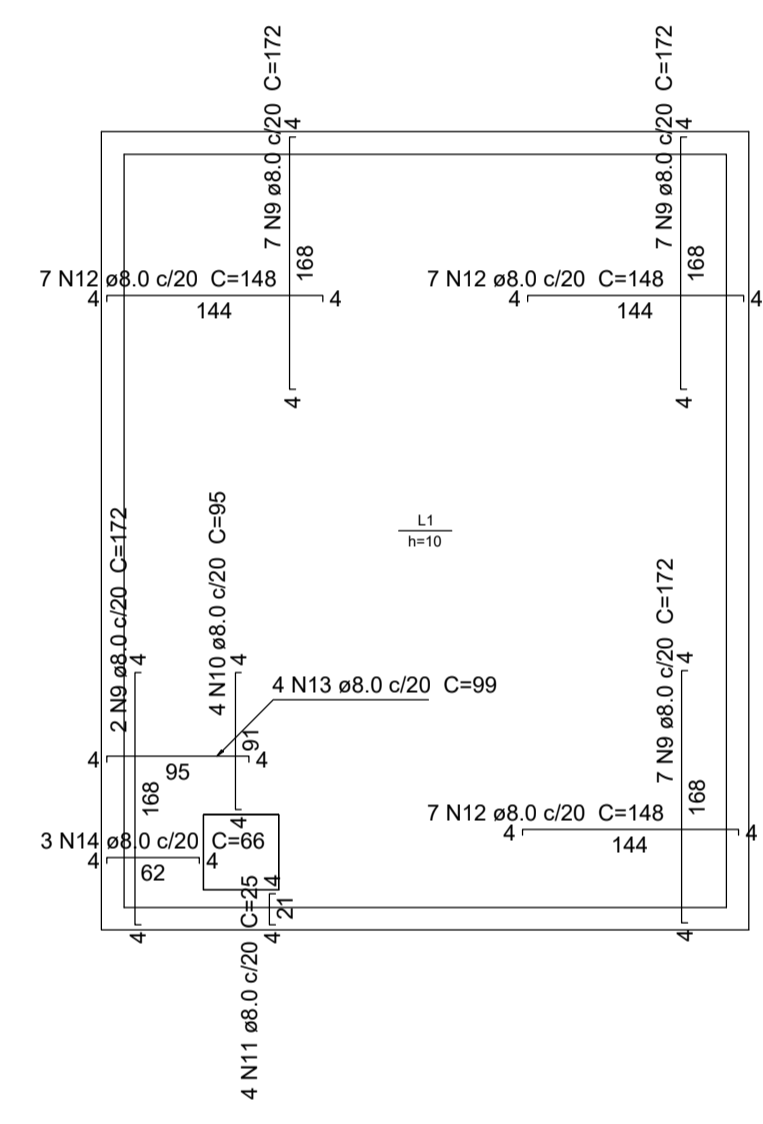

ARMAÇÃO NEGATIVA DAS LAJES DE TAMPA  
ESC. 1:50

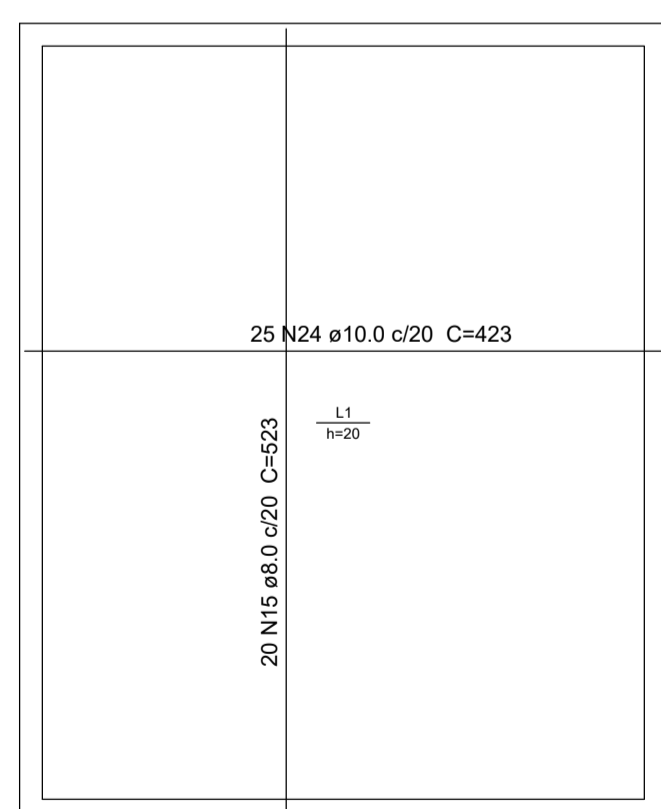

ARMAÇÃO POSITIVA DAS LAJES DE FUNDO  
ESC. 1:50

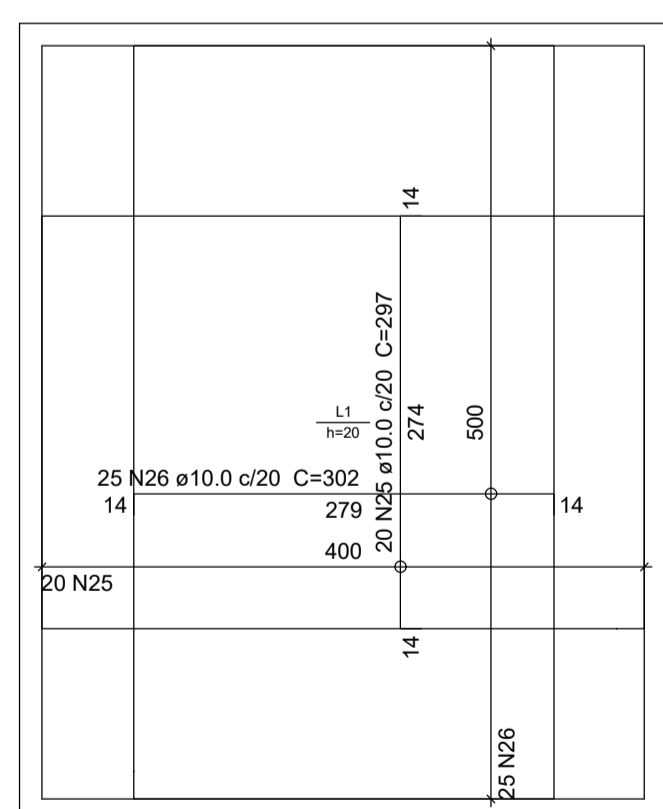

ARMAÇÃO NEGATIVA DAS LAJES DE FUNDO  
ESC. 1:50

Relação do aço

AÇO	N	DIAM (mm)	QUANT	C.UNIT (cm)	C.TOTAL (cm)
CA50	1	6.3	60	439	26340
	2	6.3	60	539	32340
	3	8.0	60	171	10260
	4	8.0	52	429	22308
	5	8.0	42	454	19068
	6	8.0	23	423	9729
	7	8.0	3	333	999
	8	8.0	3	88	264
	9	8.0	23	172	3956
	10	8.0	4	95	380
	11	8.0	4	25	100
	12	8.0	21	148	3108
	13	8.0	4	99	396
	14	8.0	3	66	198
	15	8.0	20	523	10460
	16	10.0	60	155	9300
	17	10.0	52	408	21216
	18	10.0	42	433	18186
	19	10.0	4	127	508
	20	10.0	4	157	628
	21	10.0	17	523	8891
	22	10.0	4	479	1916
	23	10.0	4	39	156
	24	10.0	25	423	10575
	25	10.0	20	297	5940
	26	10.0	25	302	7550
	27	12.5	16	284	4544
	28	12.5	8	524	4192
	29	12.5	12	424	5088

Resumo do aço

AÇO	DIAM (mm)	C.TOTAL (m)	PESO (kg)
CA50	6.3	586.8	143.6
	8.0	812.3	320.5
	10.0	848.7	523.2
	12.5	138.3	133.2
<b>PESO TOTAL (kg)</b>			
CA50		1120.5	

Volume de concreto (C-30) = 14.07 m³  
Área de forma = 130.42 m²

PEN	QDR	ESP
1	7	0.10
2	7	0.20
3	7	0.30
4	7	0.40
5	7	0.50
6	7	0.60
7	7	0.15
8	7	0.05
9	7	0.00
10	7	0.00
12	7	0.80
000	7	0.00
000	7	0.00
000	7	0.00
170	170	0.15
240	7	0.23
252	7	0.03

COMPANHIA DE SANEAMENTO DO PARÁ  
SISTEMA DE ABASTECIMENTO DE ÁGUA  
**UNIDADE DE NEGÓCIOS NORDESTE**  
SISTEMA DE ABASTECIMENTO DE ÁGUA EM VISEU/PA  
ESTRUTURAL DA CISTERNA

DIRETORIA DE EXPANSÃO E TECNOLOGIA  
USPA- PROJETO E MEIO AMBIENTE USOS

**04/05**

EMPREENDIMENTO  
COD. DO PROJETO:  
COD. DO DESENHO:  
AG-VISEU-EST-004-R0

PROJETO:	DESENVOLVIMENTO:	AGREMENSOR:	DATA:
RESP. TEC.:	DES. CAD.:	DES. DE REFERÊNCIA:	ESCALA:
ENP. ROBERTSON FREITAS	ENP. ROBERTSON FREITAS		JAN/2021 1:50

ARQUIVO: AG-VISEU-EST-001-005-R0.dwg